

GLASSWALL SPECIFICATIONS

Series GL1 Individual, Glass Panels

(Series was formerly G600)

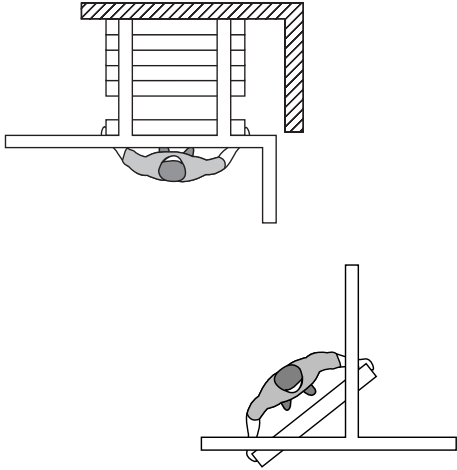

**Top Supported
Side Stack**

**Individual, Omni-Directional Panels
Manually Operated**

Maximum Opening Height: 10' 5" [3.2m]

Maximum Opening Width: Unlimited

PRODUCT OVERVIEW:

Select for Special Needs: Use in areas that you wish to divide with a physical, but not a visual, barrier and where sound control is not a requirement.

Standard Features: Panels are of glass, mechanically fastened to top and bottom horizontal rails. The support rails are of anodized aluminum.

Individual, Omni-Directional Panels: Individual, manually operated panels offer maximum room flexibility. The track system enables panels to negotiate turns and be used in alternate locations.

How to Obtain: Hufcor partitions are sold, installed, and serviced by factory-trained local authorized Distributors in the United States and by Licensees and Distributors outside the U.S.A.

Delivery: Panels are custom built for your specific project. Lead times vary due to seasonal fluctuations (average 6-8 weeks from receipt of final dimensions). Check with your Distributor for the current schedule.

Warranty: Track, carriers, and horizontal rails are guaranteed for **one year** against defects in material and workmanship. The glass is not included in this warranty.

"Standard" Product Features and Benefits:

Look for these features when comparing similar products.

- Feature:** Interlocking bottom rails
Benefit: Ensures flat setup of the partition.
- Feature:** Footbolts must be set before next panel can be positioned
Benefit: Ensures that footbolts are set, that the panel is plumb, and securely locked in place.
- Feature:** Mechanical pins hold glass through holes in glass (instead of friction)
Benefit: Provides a positive hold and ensures that the glass cannot slip from the top rail.
- Feature:** Optional self-closing 360 degree pass door.
Benefit: Push or pull this pass door for egress in either direction.

(Important note: there is a 1/4-1/2" [6-12] gap between panel joints to prevent glass from touching during panel setup. Size of gap varies due to glass tolerances.)



The standard product may be modified to fit individual job site requirements. Contact your Hufcor representative for assistance.

GENERAL SPECIFICATIONS/GLASSWALL

GL1 Individual, Omni-Directional Glass Partitions

PART 1 - GENERAL

1.01 DESCRIPTION

A. General

1. Furnish and install operable glass partitions and suspension system. Provide all labor, materials, tools, equipment, and services for glass operable walls in accordance with provisions of contract documents.

1.02 RELATED WORK BY OTHERS

- A. Preparation of opening will be by General Contractor. Any deviation of site conditions contrary to approved shop drawings must be called to the attention of the architect.
- B. All header, blocking, support structures, jambs, and track enclosures, as required in 1.04 Quality Assurance.
- C. Pre-punching of support structure in accordance with approved shop drawings.
- D. Paint or otherwise finishing all trim and other materials adjoining head and jamb of the partitions.

1.03 SUBMITTALS

- A. Complete shop drawings are to be provided prior to fabrication indicating construction and installation details. Shop drawings must be submitted within 60 days after receipt of signed contract.

1.04 QUALITY ASSURANCE

- A. Preparation of the opening shall conform to the criteria set forth per ASTM E557 Standard Practice for Architectural Application and Installation of Operable Partitions..
- B. Glass shall be clear tempered per ASTM C1048-97b.

1.05 PRODUCT DELIVERY, STORAGE, AND HANDLING

- A. Proper storage of partitions before installation and continued protection during and after installation will be the responsibility of the General Contractor.

- 1.06 WARRANTY. Track, carriers, and horizontal rails shall be guaranteed for one year against defects in material and workmanship. The glass is not included in this warranty.

PART 2 - PRODUCTS

2.01 ACCEPTABLE MANUFACTURERS

- A. Upon compliance with all of the criteria specified in this section, Manufacturers wishing to bid products similar to the product specified must submit to the architect 10 days prior to bidding complete data in support of compliance and a list of three past installations of products similar to those listed. The submitting manufacturer guarantees the proposed substituted product complies with the product specified and as detailed on the drawings.

2.02 MATERIALS

- A. Product to be top supported, Series GL1 individual glass panels as manufactured by Hufcor.
 1. Panels shall be nominally 1-5/8" [40] thick and to 48" [1219] in width.
 2. Glass shall be mechanically attached to top and bottom rails and not rely on friction and/or adhesives.
 3. All glass edges shall be polished and glass panel faces shall be a choice of
 - a. 1/2" [12] fully tempered glass
 - b. 1/2" [12] laminated glass.
 - c. 1/2" satiny translucent acid washed, full height, one side only
 - d. Optional (factory approval required):
 - Acrylic
 - Custom glass
 4. Top and bottom horizontal rail shall be anodized aluminum and incorporate brush light seals.
 5. Glass faces shall have no vertical trim. (Important note: there is a 1/4-1/2" [6-12] gap between panel joints to prevent glass from touching during panel setup. Size of gap varies due to glass tolerances.)
 6. Each panel contains a footbolt which is extended into a floor mounted receiver to stabilize and secure each panel in the opening.

- B. Weight of the panels shall be approximately 7.4 lbs. per sq. ft. for 1/2" [12] glass.

C. Suspension system:

1. Track shall be of clear anodized architectural grade extruded aluminum alloy 6063-T6. Track design shall provide integral support for adjoining ceiling, soffit, or plenum sound barrier. Track shall be connected to the structural support by min. 3/8" [10] dia. threaded steel hanger rods. Guide rails and/or track sweep seals shall not be required.
 - a. Each panel shall be supported by two 2-wheeled counter-rotating horizontal carriers. Wheels to be of precision ground steel ball bearings with heat treated and hardened races encased with molded polymer tires.

D. Finishes

1. Horizontal rail color shall be (**select one**):
 - a. Clear anodized (standard)
 - b. Bronze anodized (optional upgrade)
 - c. Stainless steel clad (optional upgrade)
 - (1) Polished
 - (2) Brushed
 - #4 brushed
 - #7 brushed
 - d. Custom painted (optional upgrade)
 - e. Powder coated (optional upgrade)
 2. Aluminum track shall be clear anodized
 - a. Optional upgrade:
 - (1) custom anodized
 - (2) custom powder coated

E. Available Accessories/Options

1. Pivot panel closure
 - a. Low profile handle (standard)
 - a. Vertical tube handle with push/pull handle one or both sides(optional)
 - b. Vertical tube handle with optional tube push bar, one side
2. Locks
 - a. Thumb turn floor lock
 - b. Keyed floor lock
3. Glass etching
 - a. Fully etched and sealed
 - b. Custom patterns
4. Pass door, full height, ADA compliant pass door, of same finish and construction as basic panels. Includes low profile handle, plunger latch to hold door closed, and a magnetic hold open to secure door while the panel is being moved.

2.03 OPERATION

- A. Panels shall be manually moved from the storage area, positioned in the opening, and footbolts set.
- B. Final partition closure to be by (select one):
 1. Pivot panel
 2. Overlapping the opening
 3. End at wall
- C. Stack/Store Panels
 1. Retract footbolts, and move to storage area. Panels are stored on stacks in storage area(s).

PART 3 - EXECUTION

- A. Installation. The complete installation of the glass wall system shall be by an authorized factory-trained installer and be in strict accordance with the approved shop drawings and manufacturer's standard printed specifications, instructions, and recommendations.
- B. Cleaning
 1. All track and panel surfaces shall be wiped clean and free of handprints, grease, and soil.
 2. Optional specialty glass requires special cleaning per instructions provided.
 3. Cartoning and other installation debris shall be removed to on-site waste collection area, provided by others.
- C. Training
 1. Installer shall demonstrate proper operation and maintenance procedures to owner's representative.
 2. Owners manuals shall be provided to owner's representative.

VERTICAL SECTION

Type 26 aluminum track is shown and is standard for panels weighing up to 500 lbs. [227 kg].

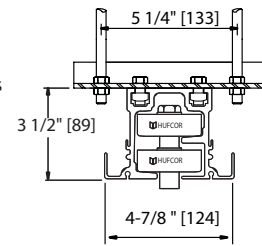
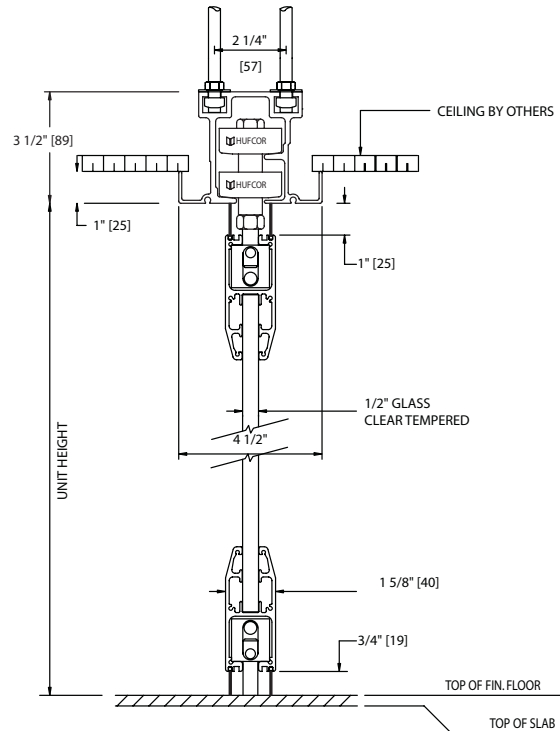

Optional Type 36 Aluminum Track
Use for panels exceeding 1000 lbs. [454 kg].
Shown with optional suspension bracket for 5-1/4" [133] spacing. Bracket also available for use with Type 26 track.

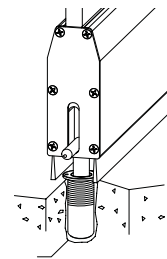

Footbolt
engages in floor receptacle to ensure panel-to-panel alignment and stability.

DETAILS

Individual, Omni-Directional Glass Partitions

HORIZONTAL SECTION

Horizontal Section with Pivot Panel Closure

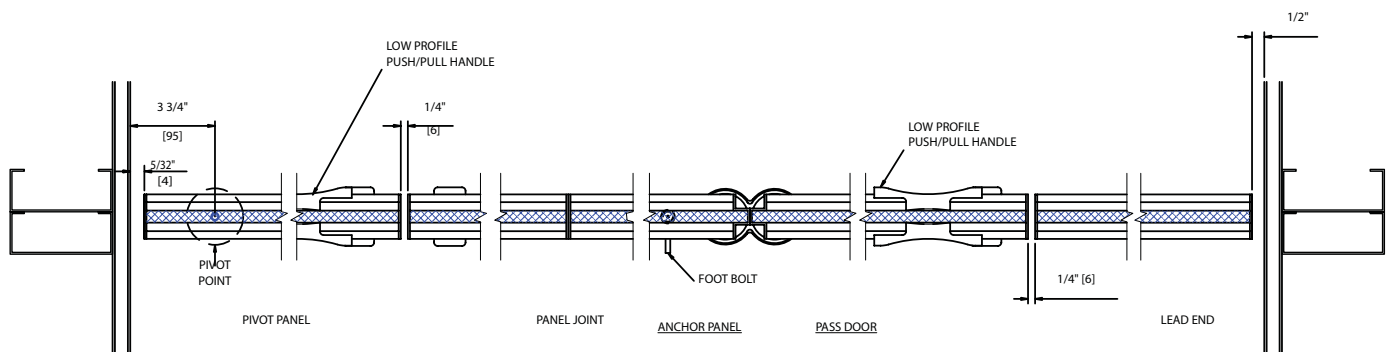

Important note: there is a 1/4-1/2" [6-12] gap between panel joints to prevent glass from touching during panel setup. Size of gap varies due to glass tolerances.

Individual, Omni-Directional Glass Partitions (cont'd)

Omni-Directional Stack Options

The Type 1 stack shown below is the most often used for simple omni-directional layouts. Types 2 & 3 are additional common stack configurations. Stacks are not limited to these configurations and may be built to fit each job requirement. Consult your Hufcor representative for design assistance.

Wall to wall opening with pivot panel closure - H Stack

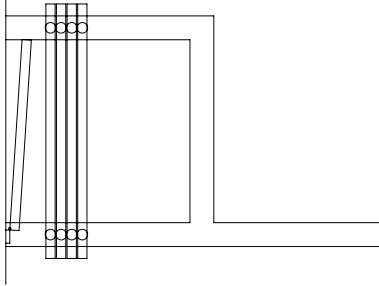

Type 1

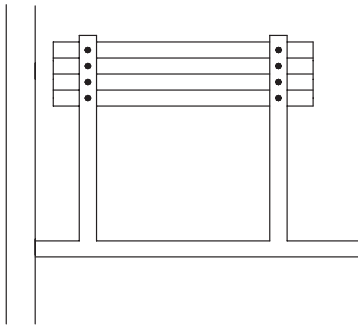

Type 2

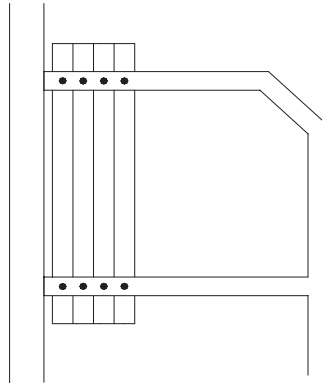

Type 3



CAUTION

Body space is needed to access the panels and move them into position. Be certain to consult your Hufcor representative before constructing walls in pocket/stack areas. This is important for all configurations.

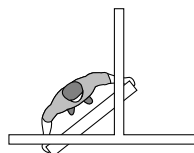

Individual, Omni-Directional Operable Glass Partitions

Stack Dimensions

Stack depth and width dimensions are based on a flat stack. Angled stacks require additional space. Contact your Hufcor Distributor for angled stack requirements.

Pivot Panel Closure



Stack Depth:

2" [51] per panel + 3-5/16" [84] using 26 track.
 2-1/2" [64] per panel + 2-9/16" [65] using Type 36 track.

Stack Width:

Panel width + 4" [101] finger clearance

Pivot Panel Closure with Push Bar



Stack Depth:

2" [51] per panel + 2-1/2" [64] using Type 26 track.
 2-1/2" [64] per panel + 2" [51] using Type 36 track.
 Add 7" [178] for tube style handle

Stack Width:

Panel width + 4" [101] finger clearance

Wall to wall opening without pivot panel



Stack Depth:

2" [51] per panel + 1-1/2" [64] using Type 26 & Type 36 track.
 Add 7" [178] for tube style handle.

Stack Width:

Panel width + 4" [101] finger clearance

Important note: there is a 1/4-1/2" [6-12] gap between panel joints to prevent glass from touching during panel setup. Size of gap varies due to glass tolerances.

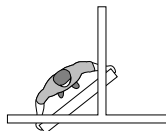

CAUTION

Body space is needed to access the panels and move them into position. Be certain to consult your Hufcor representative before constructing walls in pocket/stack areas. This is important for all configurations.

ELEVATION

Shown with Single Pass Door

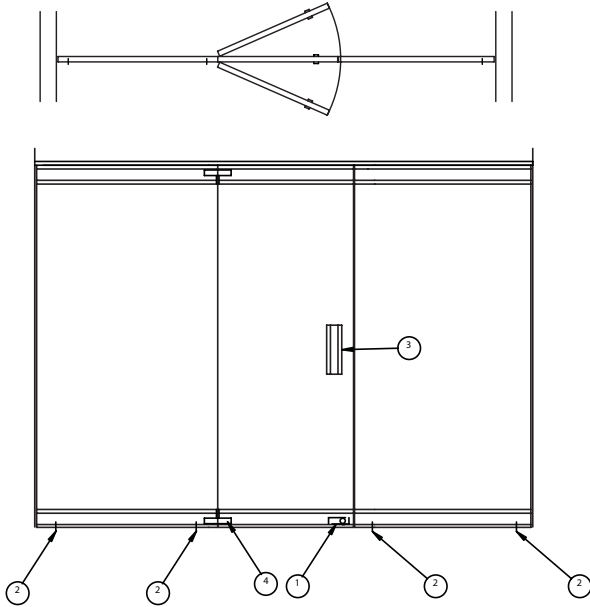

Shown with Double Pass Door

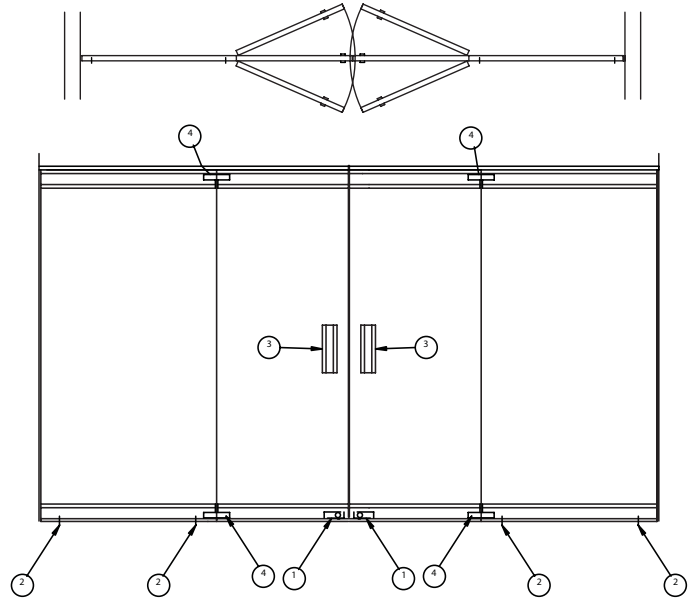

Shown with Pivot Panel Closure

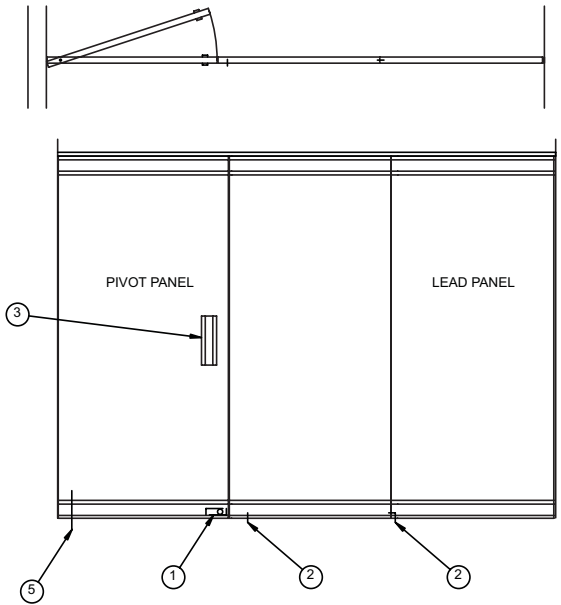

Wall to wall opening without Pivot Panel

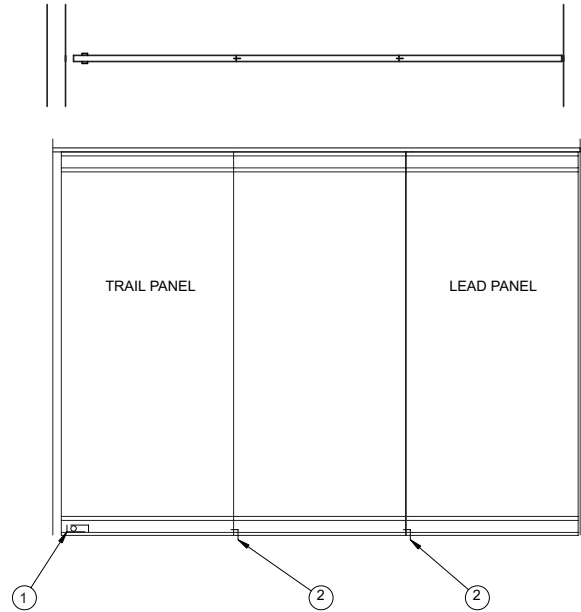

Important note: there is a 1/4-1/2" [6-12] gap between panel joints to prevent glass from touching during panel setup. Size of gap varies due to glass tolerances.

- | | |
|--|----------------------|
| 1. Standard thumb turn or optional keyed lock. | 4. 360 degree hinge. |
| 2. Footbolt | 5. Pivot block |
| 3. Low profile Pass Door Push/Pull handle supplied with every Pass Door. | |

World headquarters:

Hufcor Inc.
 P.O. Box 591
 Janesville, WI USA 53547-0591
 1-800-542-2371 ext. 214; 1-608-756-1241
 FAX: 1-608-758-8253
 E-mail: info@hufcor.com
 Internet address: http://www.hufcor.com

The manufacturer reserves the right to improve and change product without notice.

Select Hufcor products are also manufactured in the U.S. at:
 Hufcor/Airwall, Inc., 8739 E. Artesia Blvd., Bellflower, CA 90707
 1-562-634-3116 FAX 1-562-630-8203